

AGENDA ITEM FOR ADMINISTRATIVE MEETING

( ) Discussion only  
(X) Action

FROM (DEPT/ DIVISION): Dan Lonai, Administrative Services

PROGRAM: Maintenance

SUBJECT: Wiring of new classroom for OSU in the new fair building

<p>Three estimates were obtained for wiring the classroom to OSU requirements in the new fair building for Extension. The lowest estimate was from Copper Creek Electric for \$7,750. It is recommended to go with the bid from Copper Creek Electric.</p>	<p>( ) <u>ACTION REQUESTED:</u>  Approve contract with Copper Creek Electric in the amount of \$7,750</p>
--	---

ATTACHMENTS: Estimates

Date: ( 1/13/2024 )      Submitted By: (Dan Lonai)

\*\*\*\*\*For Internal Use Only\*\*\*\*\*

Checkoffs:

- ( ) Dept. Head (copy)
- ( ) Fiscal
- ( ) Legal (copy)
- ( ) (Other - List )

To be notified of Meeting: **Martie McQuain**

Needed at Meeting:

\*\*\*\*\*

Scheduled for meeting on: January 22, 2024

Action taken:

\*\*\*\*\*

Follow-up:

# Three-Bid Comparison Form for Construction Project

## Project Information

Project Name: Classroom Electrical Bids for the OSU Extension Classroom  
Project Location: 1740 E Airport Rd.  
Project Description: New 18' X2 25' Classroom  
Deadline for Completion: Pending NTP ( notice to Proceed)  
Bid Submission Deadline: N/A

## Contractor Information

Details	Bidder 1	Bidder 2	Bidder 3
Company Name	Shelco Electric	Copper Creek Electric	Double S Electric Inc
Contact Person	Tim Ottmar	Dustin Rysdom	Daryl Stewart
Phone Number	541-567-5532	541-567-9673	541-276-1141
Email Address	Tim@shelcoelectric.com	Dustin@copercreek-electric.com	Stewartx3@gmail.com
License Number	CCB# 02315	CCB#249435	CCB#168796

## Bid Details

Criteria	Bidder 1	Bidder 2	Bidder 3
Total Bid Amount	\$15,200.00	\$7,750.00	\$10,900.00
Labor Costs	\$11,250.00	N/A	N/A
Material Costs	\$3,950.00	N/A	N/A
Equipment Costs	N/A	N/A	N/A
Timeline (Start-End)	Pending NTP	Pending NTP	Pending NTP
Payment Schedule	Upon Completion	Upon Completion	Upon Completion
Warranty/Guarantees			
Insurance Coverage			
Additional Notes			

## Evaluation

Lowest Bidder: Copper Creek Electric  
Preferred Bidder: Copper Creek Electric  
Reason for Selection: Low bid

## Signature

Name: Martie McQuain  
Title: Facilities Manager  
Date: 1/10/25



Address: 860 West Elm  
 PO Box 25  
 Hermiston, OR 97838  
 Phone: 541-567-5532  
 Fax: 541-567-7312  
 CCB# 02315

**Job name:** Umatilla County OSU Extension Classroom

**Customer Contact:** Martie

**Date:** 1/6/2025

**Estimator:** Tim Ottmar - [Tim@shelcoelectric.com](mailto:Tim@shelcoelectric.com)

**Scope of work:** Install sub panel for new classroom fed from existing service panels, install branch circuit wiring in classroom for one 50 amps stove, 20 amp HVAC, refer, receptacles as per layout. Install six flat panel LED type lights in classroom controlled by three switches, Install two flat panel type LED fixtures in hallway controlled by single switch by doorway.  
 Install receptacle on exterior of north wall for refer.

<u>Includes:</u>	<u>Cost:</u>
Labor	11,250.00
Materials	3950.00
<b>Proposed Cost:</b>	<b>15,200.00</b>
<b>Proposal Expires after:</b>	<b>30 days</b>

**Not Included:**

- Material pricing after 30 days
- Electrical permit
- Prevailing wage

**Terms:** Payment due on receipt



Address: 860 West Elm  
PO Box 25  
Hermiston, OR 97838  
Phone: 541-567-5532  
Fax: 541-567-7312  
CCB# 02315

**Clause:**

*All material is guaranteed to be as specified. All work to be completed in a workmanlike manner according to standard practices. Any alteration or deviation from above specifications involving extra costs will be executed only upon written orders, and will become an extra charge over and above the estimate. All agreements are contingent upon strikes, accidents or delays beyond our control. Property owner shall carry fire, tornado and other necessary insurance. Our workers are fully covered by Workmen's Compensation Insurance. ~ **Thank you***

***Authorized Signature:***

*Tim Ottmar*

***Note:*** *This proposal may be Withdrawn by us if not accepted within 30 days from date listed above.*

***Acceptance of Proposal:***

*The above prices, specifications and conditions are satisfactory and are hereby accepted. You are authorized to do the work as specified. Payment will be made as outlined above*

---

---

***Date of acceptance:***

---

*Please sign above and date. Fax to SHELCO Electric Inc. ~ **Thank you.***

# Copper Creek Electric LLC



## COMMERCIAL PROPOSAL & CONTRACT

Copper Creek Electric llc

CCB: 249435

30588 Oldfield St

PO Box 85

Hermiston, OR 97838

[Dustin@coppercreek-electric.com](mailto:Dustin@coppercreek-electric.com)

Office:541-567-9673

Dustin's Cell:541-561-5153

Date: January 8, 2025

Customer: Umatilla County Fair Board

Contact: Martie McQuain (541)720-8181

Email: [maintenance@umatillacounty.gov](mailto:maintenance@umatillacounty.gov)

Job Description: Sub-panel and electrical for craft/sewing addition and corridor.

**This proposal includes materials and labor to complete the scope of work listed below. Changes to the scope of work or materials must be approved via a written change order from CCE llc before the work is completed:**

- Installation of one 24 space 60-amp subpanel in corridor south of sewing room fed from existing electrical service/panels.
- Installation and wiring of 8 2'x4' surface mount LED fixtures. 2 in the corridor, 6 in the sewing room.
- Electrical for 2 refrigerator outlets.
- Electrical for one electric range for cooking.
- Installation and wiring of 4 single pole switches. One for corridor lights, three for the 6 lights in the sewing room.
- Installation of two Exit signs. One in the corridor, one in the sewing room.
- Installation of 21 receptacles in the sewing room.
- Electrical for one 30amp, 240v mini-split HVAC unit. Low voltage comm. Cable to be installed by the HVAC installer.

**Notes: Please see email attachment for electrical plan layout and lights specification.**

**Contract Amount: \$7,750.00 Seven-Thousand Seven-Hundred Fifty Dollars**

**Payments to be paid within 30 Days of completed work with progressive payments at 30-Days Progress.**

Late Payments will have a 5% monthly fee imposed in accordance with Oregon Laws not exceeding 30% annually,

Customer Acceptance \_\_\_\_\_ Date \_\_\_\_\_

*All Proposals are valid for a 30-day period. After 30 days the proposal must be resubmitted.*

***Thank you for the opportunity to earn your business.***

Mech rm

30 Amp Main split Out

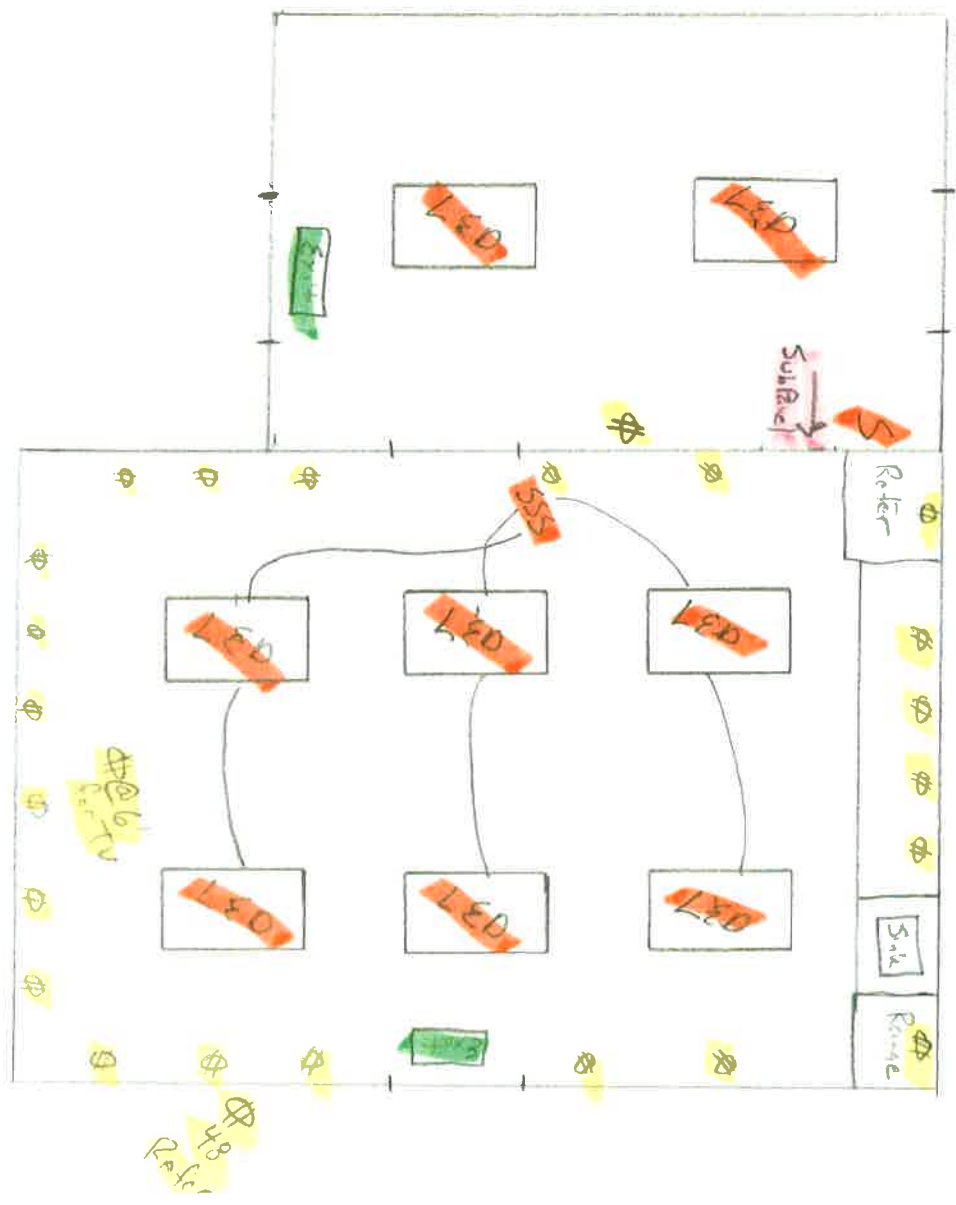

Project		Catalog #		Type	
Prepared by		Notes		Date	

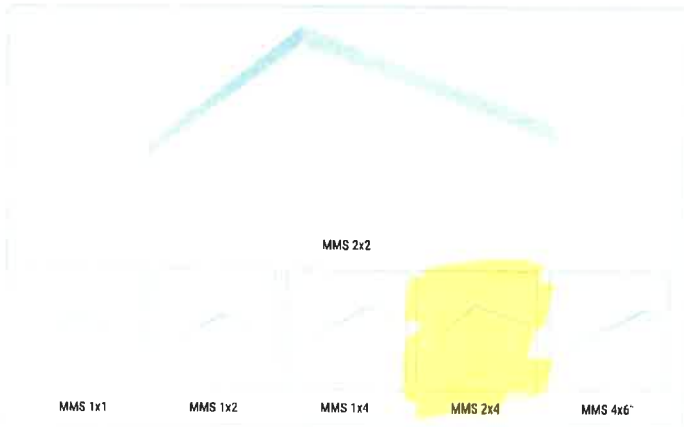

# Metalux

## MMS Multi-mount Selectable

1x1 / 1x2 / 4x6" / 1x4 / 2x2 / 2x4  
Direct Mount LED Backlit Panel

### Typical Applications

Offices • Education • Healthcare • Retail

### Product Certification



### Product Features



### Interactive Menu

- Order Information [page 2](#)
- Product Specifications [page 5](#)
- Product Warranty

### Top Product Features

- Versatile mounting: Surface (no surface mount kit needed), recessed, suspended (with kit) or wall mount
- 1' x 4', 2' x 2', 2' x 4' with standard 90 CRI, (3) CCT Selectable: 3500K, 4000K, 5000K
- 1' x 1', 1' x 2', 6" x 4' with standard 90 CRI, (5) CCT Selectable: 2700K, 3000K, 3500K, 4000K, 5000K
- Selectable switches are located on top of the junction box, for quick adjustment before and after installation
- 0-10V continuous dimming to 5% for increased energy savings
- Acrylic micro-optics provide uniform illumination across the entire lens

## MMS Dimensions

2' x 4'

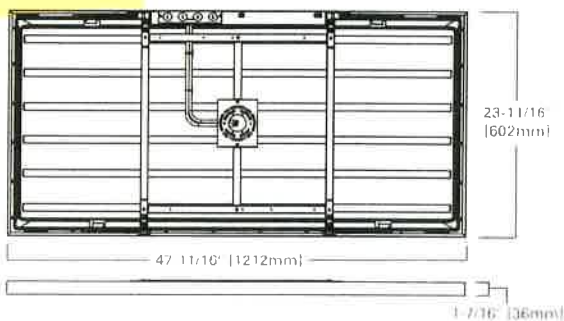

1' x 4'

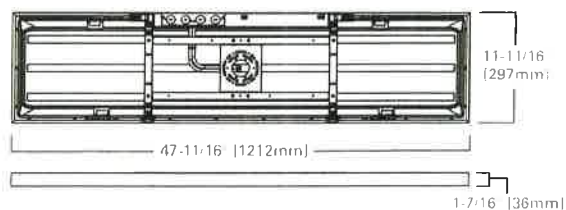

2' x 2'

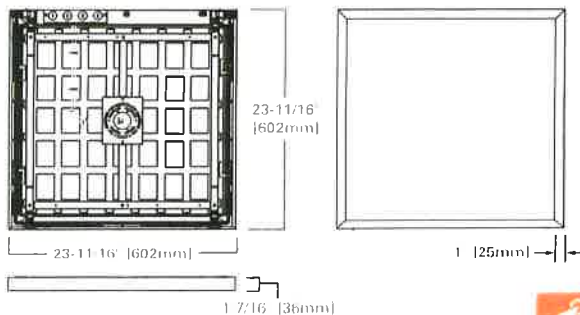

additional product diagrams



---

## 740 E Airport Way Hermiston

message

---

**Daryl Stewart** <stewartx3@gmail.com>

Fri, Jan 10, 2025 at 2:07 P

: Martie McQuain <martie.mcquain@umatillacounty.gov>

The following bid is for the requested electrical improvement at the above address. This bid is all inclusive as pertains to the documents provided, including the Electrical scope as well as the electrical diagram.  
Any and all deviations from the documents provided will be completed on a cost plus basis.

Total bid: \$10,900.00

Thank you for your consideration,  
Daryl Stewart  
Double S Electric Inc  
175 Hwy 82  
Lostine, OR 97857  
(541)276-1141

CCB#168796  
BCD#C134