

LEGEND:

THE PURPOSE OF THIS SURVEY IS TO DO A BOUNDARY LINE ADJUSTMENT TO MORE NEARLY MATCH THE LINE OF POSSESSION BETWEEN LOTS 2 & 3, BLK. 2. "PETERSON ADDITION".
 I RETRACED ASCHER'S 1965 PLAT OF "PETERSON ADDITION" TO ESTABLISH THE ORIGINAL AND REVISED LOT LINE BETWEEN LOTS 2 & 3.

REGISTERED
 PROFESSIONAL
 LAND SURVEYOR
G. Dennis Edwards
 OREGON
 JULY 16, 1971
 G. DENNIS EDWARDS
 9 5 1
 RENEWS 12/31/2001

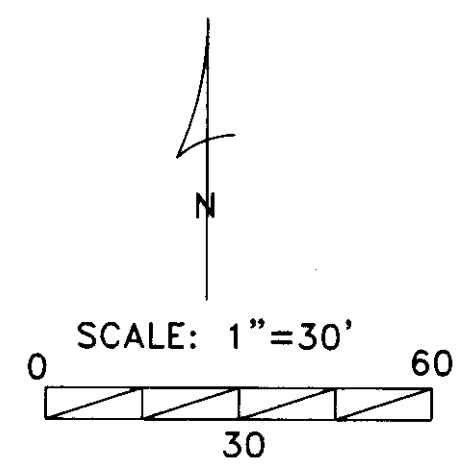

LEGEND:

- FOUND MONUMENTS AS NOTED
- SET 5/8"X30" IRON REBAR WITH PLASTIC CAP #951
- (000) OF RECORD PLAT OF "PETERSON ADDITION" ASCHER 1965

RECEIVED BY
 Umatilla County Surveyor
 Date 11-00
 Rec'd By KK
 No. 00-248-A

SURVEY FOR DENNY EDWARDS & TOM DAVIS
 IN LOTS 2 & 3, BLK. 2, "PETERSON ADDITION",
 IN SE 1/4, SEC. 18, T 5 N, R 28 E, W.M.,
 CITY OF UMATILLA, UMATILLA COUNTY, OREGON
 5/5/2000 JOB# S9503027-A
 EDWARDS SURVEYING P.O. BOX 763
 541-567-3336 HERMISTON, OREGON 97838
 DRAWN BY NJF